

Industrial Gland Kits

BW Brass Gland Kit



Application

- > Indoor type for SWA cable BW - Series

Features & Benefits

- > Brass indoor gland and accessories
- > For galvanized-steel single-wire armour plastic or rubber sheathed cables
- > For use in dry, dust free, situations
- > Provides mechanical cable retention and electrical continuity via armour locking mechanism
- > Kit comprises:
 - BW Gland
 - Brass earth tag
 - Zinc plated steel locknut
 - PVC shroud
- > 2 per kit up to and including 25mm size

Technical Data

- > To BS6121-1
- > CuZn39Pb3 extruded brass alloy used for guaranteed strength and performance
- > Service temperature range -20°C to +90°C



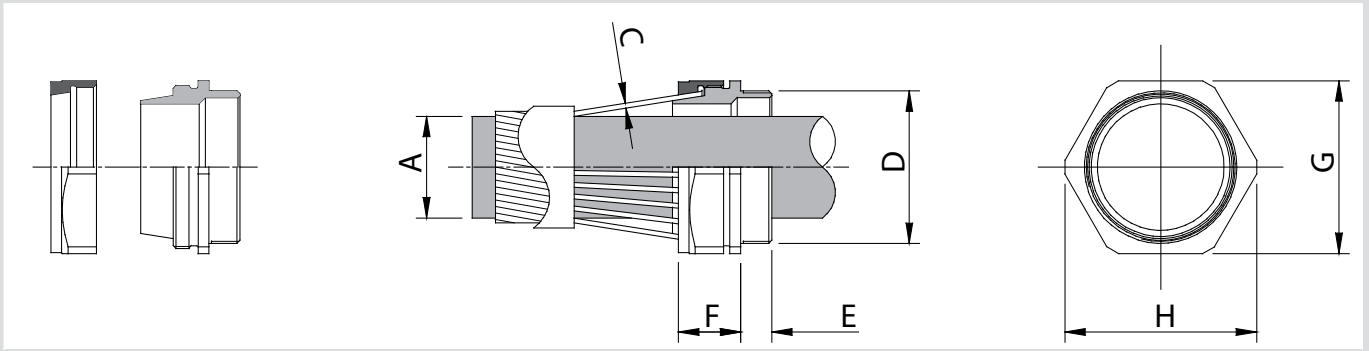

Gland Details

Cable Dimensions mm		Kit Reference			Gland Dimensions mm				
Under Armour Diameter A Max	Armour Wire Diameter C	Size	Design Number	Items Per Kit	Entry Thread		Approx. Length From Shoulder F	Hexagon Size	
					Size D	Length E		Across Flats G	Across Corners H
11.6	0.9	20S	BW20SK	2	M20×1.5	10	24	22.0	24.9
13.9	0.9/1.25	20	BW20K	2	M20×1.5	10	25	27.0	30.5
19.9	1.25/1.6	25	BW25K	2	M25×1.5	10	26	37.6	42.2
26.2	1.6/2.0	32	BW32K	1	M32×1.5	10	28	47.3	53.6
32.1	1.6/2.0	40	BW40K	1	M40×1.5	15	25	50.0	57.0
44.0	2.0/2.5	50	BW50K	1	M50×1.5	15	36	70.1	77.2
55.9	2.5	63	BW63K	1	M63×1.5	15	30	80.0	87.4
61.9	2.5	75S	BW75SK	1	M75×1.5	15	40	85.0	95.0
67.9	2.5	75	BW75K	1	M75×1.5	15	40	98.8	109.2